

**REDUCING THE REACTIVE POWER CONSUMPTION OF AIR SENDING DEVICES****To'ybojev O.U.**

Bukhara state technical university

**Annotation**

This article addresses the issue of achieving energy savings by reducing the reactive power consumption of air propellers used in wastewater treatment plants. The calculations are based on the example of air pumps at the wastewater treatment plant of Bukhara Regional Limited Liability Company "Suv TaminoT" (LLC).

**Key words**

Sewage, aeration, air propulsion, asynchronous motor, reactive power, power factor, energy saving.

**Аннотация**

В этой статье очистка сточных вод вопросы достижения энергосбережения за счет снижения потребляемой реактивной мощности воздушных движителей, используемых на очистных сооружениях. Расчеты выполнены на примере воздушных насосов на очистных сооружениях Бухарского областного общества с ограниченной ответственностью «Сув Таьминот» (ООО).

**Ключевые слова**

сточные воды, аэрация, пневматические приводные устройства, асинхронный двигатель, реактивная мощность, коэффициент мощности, энергосбережение.

In our country, special attention is paid to the creation of high-energy-efficient systems by creating opportunities for rapid control and management of technological parameters in various sectors of the economy, including air-driving devices in sewage treatment plants. It is known that in the process of purification of flowing water, as the main consumer of electricity, air driving devices that provide aeration of the sediment mixture are indicated. (65% or more) [1, 2].

The high value of reactive power in air driving devices is due to the following listed reasons:

- Asynchronous motors in driving devices choose from the air to resist power and operating conditions. Because the inductive resistance of Phase rotor asynchronous motors is high, the rotor will have more reactive power consumption than short-circuited asynchronous motors. Hence reactive power consumption is lower when the speed of which one is in electric motors with the same type and capacity is higher.

- Driving devices will result in a full and uneven non-air overload on time.

- Load-free operation of driving devices.

- Support of an electric motor with a high capacity in the case of low-power air

Drive devices.

- The use of electric motors in nominal power drive devices increases the air diffraction of magnetic flux by a factor of and consequently the reactive power consumption increases.

- The use of electrical equipment that has come out of work or badly repaired: for example, do not densely leave the rotor steel tin, the number of stator chulgami dies should be less than the number of primary ones, etc. a decrease in the number of hogs by 10% increases the motor salt gait by 25%, which leads to an increase in reactive power consumption by 6 – 8%.



The difference in the size of the Rotor steel to 10 mm leads to an increase in the reactive power consumption by 15 – 30%.

➤ The increase in the voltage of the current in the network to several volts when the drive devices are running in low-load mode leads to an increase in the inductive consumer magnetizing current, resulting in an increase in reactive power consumption.

➤ The sinusoid of the voltage in the network is broken, as a result of the presence of devices with a capacitor and the presence of an electric consumer with an alternating ferromagnetic core operating in a mode close to the saturation mode. As a result, in the asynchronous motor of air driving devices, an additional power drop occurs in the influence of nonsinusoidal voltage, which reduces the operating life of the insulation.

The relative value of the voltage for the  $\mu_s$  relative value of the static torque at different loads of the asynchronous motor in the air drive unit will be equal to  $\gamma = \sqrt{\mu_s}$ . Based on these indicators, we determine the maximum load on the torque of the asynchronous motor [3, 4, 5, 6]:

$$b_s = \frac{b_n}{\mu_s} \gamma^2$$

We determine the rated rotor current using the following formula:

$$\frac{I_2}{I_{2n}} = \sqrt{\mu_s \frac{b_n + \sqrt{b_n^2 - 1}}{b_s + \sqrt{b_s^2 - 1}}}$$

and the real value:

$$I_2 = I_{2n} \sqrt{\mu_s \frac{b_n + \sqrt{b_n^2 - 1}}{b_s + \sqrt{b_s^2 - 1}}}$$

ated value of rotor roll:

$$I_{2n} \approx \cos \theta_n \quad I_{1n} = \frac{P_n}{\eta_n \cos \theta_n \sqrt{3} U_1}$$

Here: phase nominal current of:  $I_{1n}$  – stator side.

Motor magnetic system rated value of magnetization current:

$$I_{\mu n} = \sqrt{I_{1n}^2 - I_{2n}^2}$$

The relative value of the magnetization current for different values of frequency and voltage is determined from the universal magnetization description of the asynchronous motors presented in the picture.

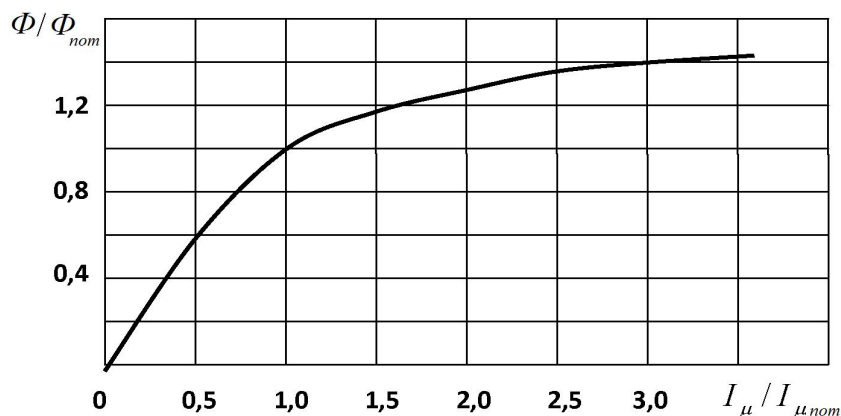

1-picture. Universal magnetization description of asynchronous motor ( $I_{\mu n}$  – rated voltage and frequency magnetization current)

We determine the relative magnetic flux by substituting the relative values of the frequencies and voltages in the expression given for the ordinate axis, denoting the relative value



of the magnetic flux between the asynchronous motor stator and the rotor in the description  $\frac{\Phi}{\Phi_{nom}}$  we determine the relative value of the magnetization current corresponding to it  $\frac{I_{\mu}}{I_{\mu}}$  and based on these values  $I_{\mu}$  – we determine the magnetization current.

We determine the sine and cosine values of the angle between the stator current and the network voltage.

$$\sin \varphi' = \frac{1}{\sqrt{2 b_s (b_s + \sqrt{b_s^2 - 1})}}$$

$$\cos \varphi' = \sqrt{1 - \sin^2 \varphi'}$$

We determine the value of the stator phase current.

$$I_1 = \sqrt{(I_{\mu} + I_2 \sin \varphi')^2 + (I_2 \cos \varphi')^2}$$

We determine the power coefficient of the asynchronous motor.

$$\cos \theta = \frac{I_2 \cos \varphi'}{I_1}$$

We calculate the reactive power that the asynchronous motor consumes from the network.

$$S = \sqrt{3} \gamma U_l I_1$$

$$Q = S \sin \theta$$

Based on the nominal parameters of the asynchronous motor in the air drive unit and the equations above, we determine the amount of reactive power consumed by the air drive unit at different loads.

1-table. Rated performance of the asynchronous motor in the air drive unit.

	$P_n$	$\omega_d$	$s_n$	$b_n$	$b_{it}$	$d_i$	$\eta_n$	cc
	k	1	(	(	(	(	(	(
W	/s	-)	-)	-)	-)	-)	-)	-)
00	2	1	0	2	1	6	0	0
	57	,013	,3	,3	,0	,94	,92	

Reduction of reactive power consumption is carried out mainly by capacitors, synchronous motors, compensators, cross-filters and semiconductor static reactive energy sources. Currently, condenser batteries with the highest technical economic performance are widely used in the coating of reactive power. The calculation of the capacitance of capacitors, which will be necessary when coating reactive power, is carried out by the following formula:

$$C = \frac{P}{\omega U^2} (tg \varphi_1 - tg \varphi_2),$$

Here, P – is the active power of the air drive device,  $\omega = 2\pi f$  – angle frequency, U – network voltage,  $\varphi_1, \varphi_2$  – is the angle between the current vektori and the network voltage before and after covering the reactive power.

The capacity of the capacitor batteries is determined by the following formula:

$$Q = P(tg \varphi_1 - tg \varphi_2).$$



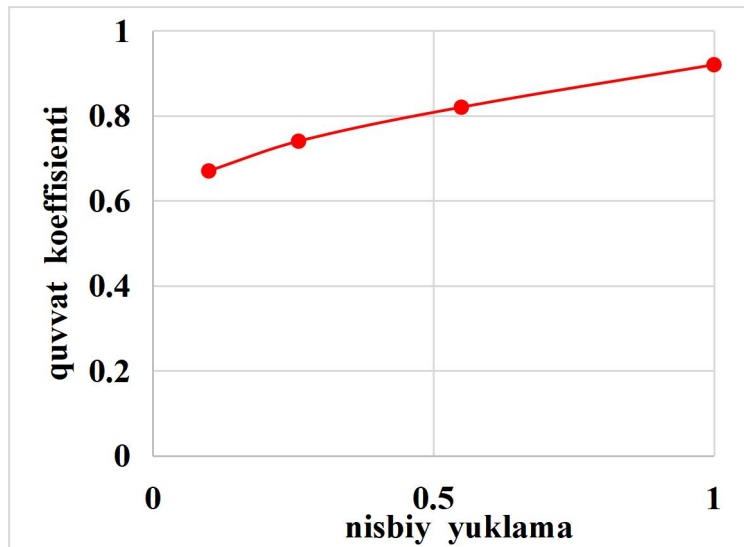

2- picture. The power coefficient of the air Drive device at different loads.

For each individual consumer, the installation of its own calculated 1 - reactive power compensation devices ( 3- picture) will relieve the power supply networks from excessive reactive power overload and provide the maximum economic efficiency.

The installation of capacitors batteries, calculated for several groups of consumers, leads to the effective use of these capacitors.

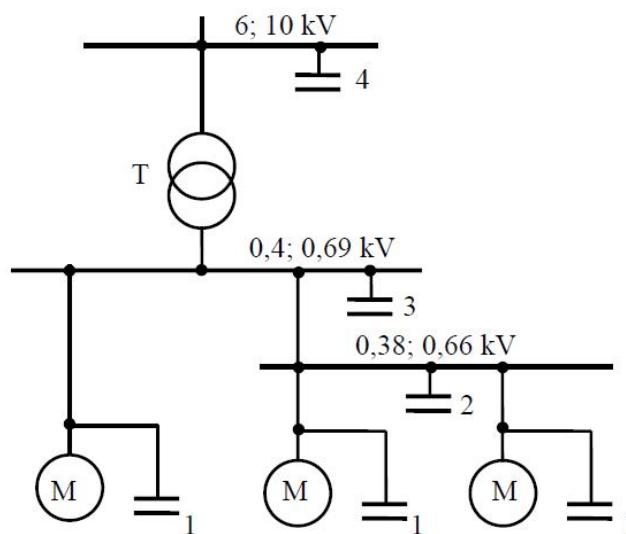

3- picture. Static capacitors installation options: 1 - 4-capacitor batteries.

Centralized compensation is carried out by connecting the capacitor batteries (3) to the tires of the transformer substation secondary voltage, thereby eliminating the reactive power load on the Transformers and supply lines. However, the secondary voltages of the NIMH station do not get rid of the reactive power load. Just as well as the capacitors connected to the side of the primary voltage of the substation, which prevents the battery and the external electrical network from reacting to the power load, the secondary voltage does not get rid of these loads on the side and on the connected consumers.

As can be seen in the picture 2, at different loads the device consumes different reactive power. Therefore, the failure to automatically adjust the reactive power leads to a decrease or increase in voltage, resulting in the failure of some devices (mainly capacitors).



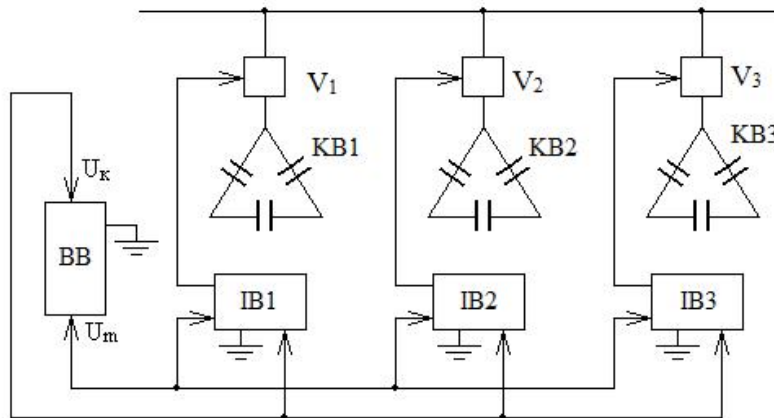

4- picture. Multi-stage automatic control scheme of reactive power

In order to eliminate such cases, we use the automatic compensation block scheme of reactive power, which is presented in picture 4. This management scheme is based on multi-stage management of capacitor batteries (CB) capacity in alternating current chains. Multi-stage management is relatively sensitive to single-stage management.

This device prescribes (BB) and blocks of execution (IB) configured from. Source to the instruction (BB) block ( $U_m$ ) and input ( $U_k$ ) voltage is given Impact signal generated at  $BB \pm \Delta U = (U_m - U_k)$  transmits to the execution block (IB). The execution block disconnects or connects a certain part of the capacitors.

The purpose of applying the controlled capacitor batteries is not only to compensate for reactive power, but also to keep the voltage transferred from the network during the maximum and minimum loads without changing the set value.

#### Results:

1. The reactive power of the air Drive devices in the wastewater treatment plants consumed at different loads was determined.
2. The main methods of reducing the reactive power consumption were analyzed and a multi-stage automatic control scheme of condenser batteries for the air Drive device was selected.
3. The power coefficient increased from 1,03 to 1,21 times when the charge in the air drive unit changed in the range of 30-100% by providing the meory value of the reactive power consumption.

#### References:

1. Шипулин Ю.Г., Махмудов М.И. Приборы и методы контроля параметров технологических сред в системах очистки и использования производственных сточных вод. Монография. -Ташкент: Fan va texnologiya, 2018. 215 с.
2. Махмудов М.И., Қо`зиёв З.Е. "Elektr mexanik tizimlarda energiya tejankorlik. O`quv qo`llanma." Вухоро: «Durdona». 2020. 112 б.
3. В.В. Москаленко "Электрический привод" Москва: Академия, 2007.
4. М.М. Кацман "Справочник по электрическим машинам" Москва: Академия, 2005.
5. Г.Г. Соколовский "Электроприводы переменного тока с частотным регулированием" Москва, Россия 2006.
6. Р.Ф. Бекишев, Ю.Н. Дементьев "Электропривод" Москва: Юрайт, 2016.

